



# FLIGHT PACK

## AIR DATA SYSTEM FP10-s5V



## INSTALLATION MANUAL

### Tasman Instruments

33 the Crescent Belgrave Hts.  
Victoria Australia 3160  
Ph. 613 9754 7211  
Fax. 613 9752 5002

Email: [info@tasmaninstruments.com.au](mailto:info@tasmaninstruments.com.au)  
[www.tasmaninstruments.com](http://www.tasmaninstruments.com)

## Introduction

The Tasman Instruments **Flight Pack** is a sensor package that connects to a Tasman Variometer and external GPS.

The FP10 and Variometer combination generates a complete air data set and, with an external GPS connected, provides serial data to drive a variety of flight software installed on a PDA. See Fig 1.

The FP10-s5V also offers an **optional** high efficiency regulated power supply for providing power to the PDA and GPS from an external +12 volt battery. Both regulated and 12 volt supplies are available at the GPS connector.

This type of data has previously only been available from flight computer systems.

Fig 1.

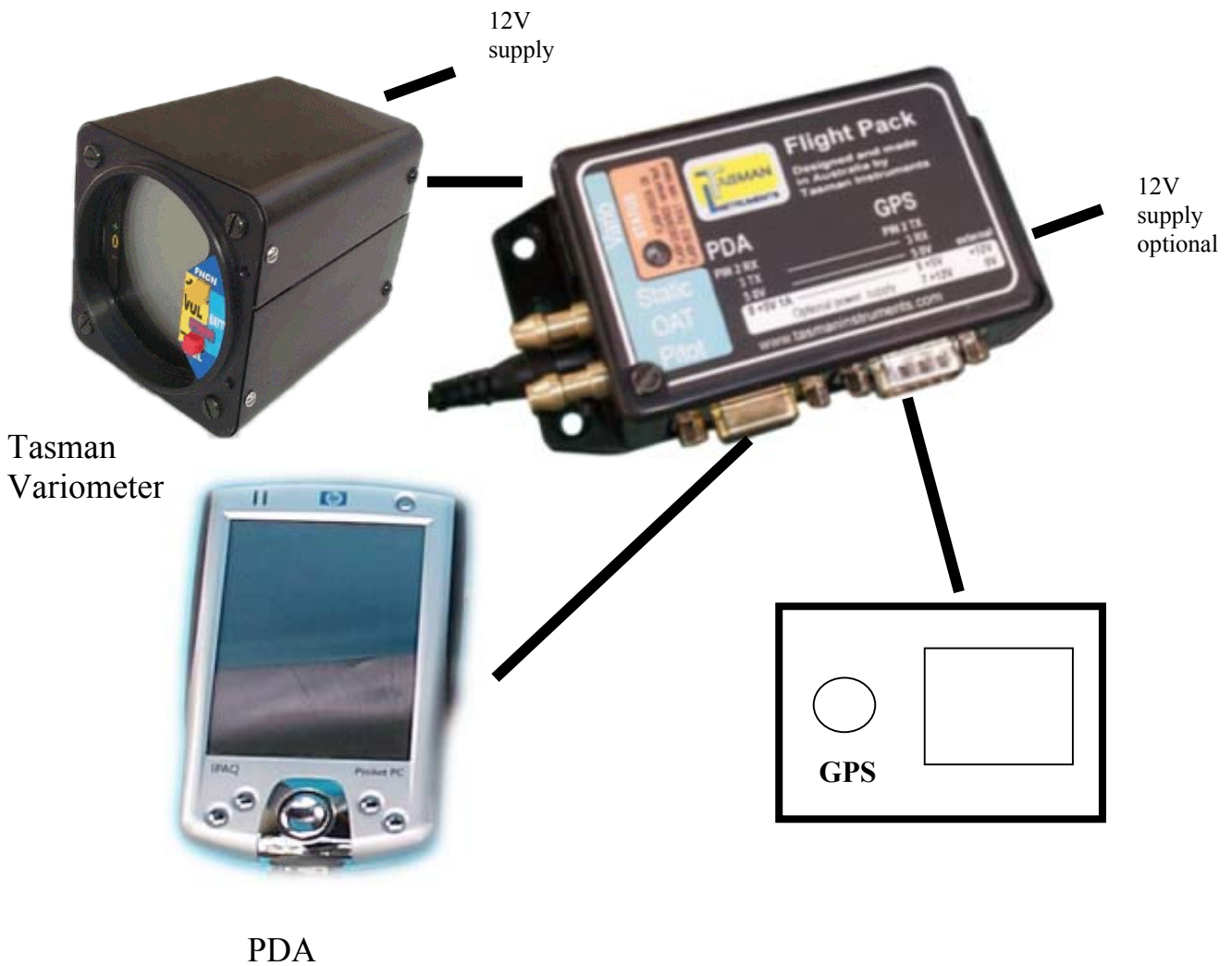

## Features

- Three years warranty. See warranty section.
- The Tasman **Flight Pack** uses the latest digital sensor technology for stable and reliable operation with low power consumption.
- Simple installation with no external power connections required and standard cable connectors are used. Compact dimensions and lightweight, robust construction and no panel space requirement.
- The FP10 has been developed with reliability as a primary requirement. All hardware is monitored for correct operation and in the event of an exception/fault the data will default to zero for the affected system. As a result the system will not “hang” but continue to operate.
- Outside Air Temperature (OAT) is measured for accurate True Air Speed (TAS) measurements.
- Adjustable baud rate and diagnostics available: see maintenance manual.
- Option of managing power supply to PDA and GPS.
- Status monitoring dual colour LED.

## Attention



- The organisation or owner performing the installation is responsible for ensuring that the FP10 installation complies with requirements of airworthiness and the installation is done professionally.
- FP10 is not to be used as a replacement for primary flight instruments.
- The FP10 is for recreational use only.

The pilot is always responsible for safe operation of an aircraft and in flight decisions.

## Installation

Materials supplied:

FP10

Data cable for connection to Variometer.

2 T pieces

This document

NOTE: The Tasman Variometer will require a software revision of ver 3.2 or later for operation with the FP10. This revision has been supplied since late 2006. Contact Tasman Instruments or your dealer for information or upgrade.



Ensure aircraft battery is disconnected before commencing installation.

Find a suitable location behind the panel and away from direct sunlight. Consider cable runs and plumbing requirements when choosing a location. Secure the enclosure with hardware or good quality Nylon ties. Cables for connection to a variety of combinations of GPS and PDA can be obtained from Cumulus Soaring, Inc. [www.cumulus-soaring.com](http://www.cumulus-soaring.com).

## Temperature Probe

The Temperature probe needs to be exposed to a supply of outside air, normally from the ventilation duct system. Secure with ties. NOTE: TAS system will still operate without the temperature probe, but in this case the ISA<sup>(1)</sup> will be used. The error could be 5-10% at 10000ft.

The Tasman Variometer will normally be supplied with a blank inserted in the 6 way connector. This will need to be removed for the data cable to be connected.

(1) International Standard Atmosphere 25degC at MSL

## Plumbing

Where possible the Pitot and Static should be connected to an independent Pitot system such as a Multiprobe or second Pitot, perhaps mounted on the fin. If the installation is connected to the a/c instrument plumbing use a good quality tubing such as a Tygon or silicon of 4.8mm (3/16") using the T pieces supplied. Check the Pitot system for leaks according to the a/c manual.

### WARNING:



Do not supply pressure to the Pitot /Static ports as damage may occur to sensors.

### Test

Power the Tasman Variometer and confirm operation of Flight Pack by monitoring the Status LED. Power GPS and PDA and confirm GPS connected on the navigation software in use. Note: XCSoar 5.1.6 or later is required, select "Generic" in device A/B. For baud rates other than 4800 refer to the FP10 maintenance manual or contact Tasman Instruments.

### Power supply

If the optional PDA power supply is fitted, the wiring for connection to the external battery requires an aircraft qualified wire of 22g or greater, via a circuit breaker or fuse of 1 or 2 amp rating. The power supply is internally polarity and overload protected. This power supply only connects to pin 8 and returns to pin 5 of the PDA 9 pin connector and nowhere else. Confirm power on by presence of LED on, at the power connector. See fig 3

**Pin Numbering/cables**



Pin 2 GPS data out  
 Pin 3 GPS data in  
 Pin 5 0V common  
 Pin 8 +5V option

GPS connector

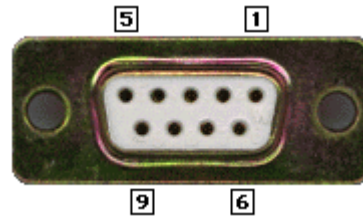

Pin 2 PDA data in  
 Pin 3 PDA data out  
 Pin 5 0V common  
 Pin 8 +5V option  
 Pin 7 +12V option

PDA connector

Cable connections Fig 2

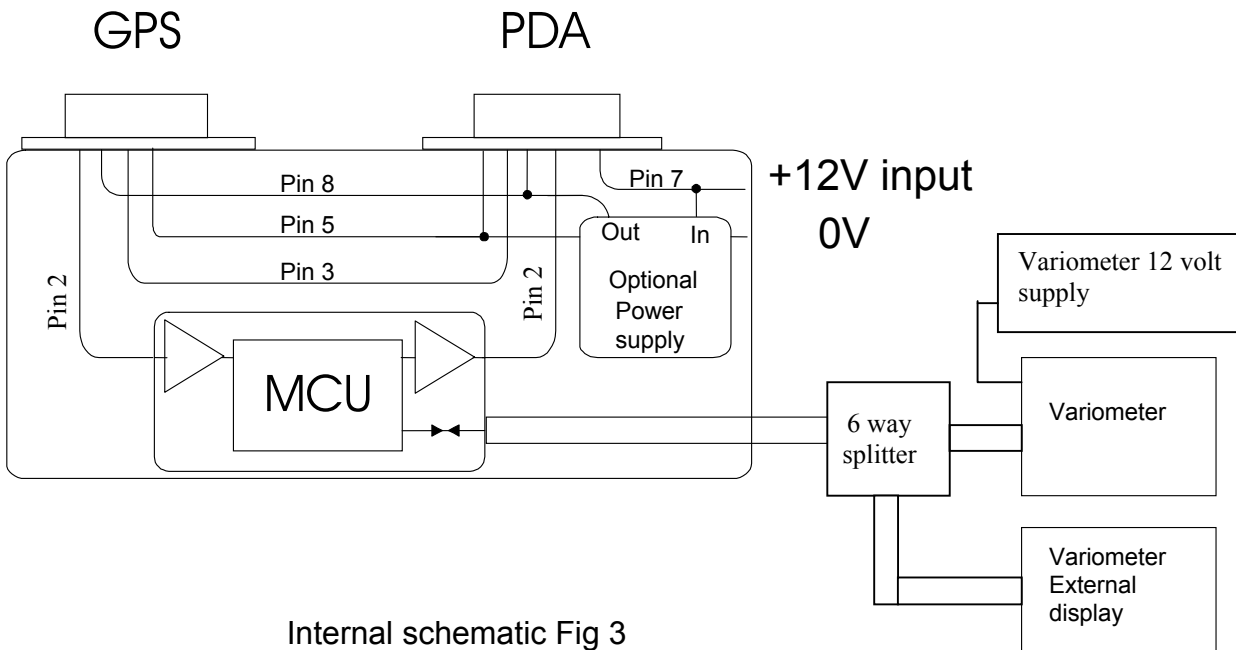

Internal schematic Fig 3

Variometer cable configuration for connection between Tasman Variometer and FP10 fig 4



Connector orientation 6 way cable. Standard length 450 mm.  
 Other lengths on request.

## Warranty

Warranty is very simple. You return a faulty instrument to Tasman Instruments within a period of three years after purchase and it will be repaired at no cost. The following conditions apply:

- Customer is liable for all shipping costs.
- Customer will contact Tasman Instruments or their agent prior to shipping.
- Returns must be well packed, they must be marked “**RETURN TO MANUFACTURE FOR REPAIR**” else taxes and custom clearance fees may be payable.
- Packages need to contain with the Instrument, the return address, a email contact and description of the fault. The customer is responsible for any loss or damage of the Instrument during transport.

## Specifications.

SIZE	H.28mm, W.60mm, D.110mm.
MOUNT	behind panel
WEIGHT	131grams (plus cables)
POWER	15mA approx
ASI ACCURACY	1%+/-1knot
ASI RESOLUTION	1 knot
ALT ACCURACY:	2 meters –1000ft to +10000ft
DISPLAY UNITS	NA.
ALTITUDE	-1000ft to 50000ft.
OPERATING TEMP	-10 to 70 deg. Centigrade non condensing
OPTIONS.	+5v 1 amp PDA power supply. Other voltages on request 6 way data cable splitter for rear display

For further information contact:

Tasman Instruments  
33 the Crescent Belgrave Hts.  
Victoria Australia 3160  
Ph. +613 9754 7211  
Fax. +613 9752 5002  
Email: [info@tasmaninstruments.com.au](mailto:info@tasmaninstruments.com.au)  
[www.tasmaninstruments.com](http://www.tasmaninstruments.com)