

RAM[®] Mounting Systems

PATENTED & PATENTS PENDING



NPI has a Lifetime Warranty on all RAM Mounting Systems and a Limited Warranty on all electronic components. Detailed information regarding these warranties may be accessed on our web site at www.ram-mount.com

NPI[®]

National Products Inc.

Tel: (206) 763-8361 Fax: (206) 763-9615

Web Site: <http://www.ram-mount.com>

e-mail: info@ram-mount.com

RPR-182-C05-INS

OWNERS MANUAL RAM[®] POWERED DOCKING CRADLE

PATENTED & PATENTS PENDING
For iPAQ[™] Handheld Computers



Charging/Serial Docks for iPAQ Handhelds

(Fits All iPAQ Series)

exception 1900 series

Provides constant charging and power for iPAQ electronic device in 12 to 28 Volt DC environments. Supplied wire harnesses allow for null or non-null modem cables. Includes fused coiled power cord with cigarette lighter plug and straight type power cord for hard wire applications (add to 2 Amp fused circuit only).

**PLEASE SEE IMPORTANT INSTRUCTIONS
INSIDE BEFORE MOUNTING YOUR IPAQ !**

CONTENTS, DESCRIPTION & ASSEMBLY INSTRUCTIONS

Before proceeding with assembly of powered docking cradle, check the contents of package to make certain all parts are included. If any parts are missing, please contact NPI for a replacement part at: support@ram-mount.com

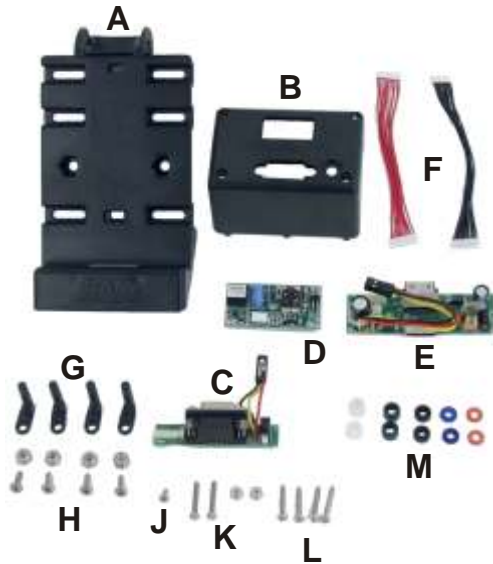

- A. 1 qty. RAM Main Plastic Housing
- B. 1 qty. RAM PCB Plastic Cover
- C. 1 qty. Input / Output Printed Circuit Board
- D. 1 qty. Power Printed Circuit Board
- E. 1 qty. IPAQ Male Connector Printed Circuit Board
- F. 1 qty. each Null Modem Wire Harness (RED), Non-Null Modem Wire Harness (BLACK),
- G. 4 qt. Side Adjusting Retaining Arms
- H. 4 qty. each #6-32 X 3/8" Machine Screws and Nylock Nuts
- J. 1 qty. #4 X 1/4" Screw
- K. 2 qty. each #4-40 x 3/4" Hex Head Machine Screw & Nylock Nut
- L. 4 qty. #6 X 3/4" Sheet Metal Screw
- M. 2 qty. each Spacers: White 1/4", Green 3/16", Black 1/8", Blue 1/16", Red 1/32"

First determine what type of connection you require for the serial port. We offer 2 different wire harnesses, a non-null-modem (**Black**) and null modem (**Red**). To determine what type you require, contact the manufacturer of your electronic device that you are attaching to the powered docking cradle. Once determined, select the appropriate colored wire harness and attach it to the corresponding PCB's **G & H** as shown in the **STEP 1** photo. Note, the ends have different numbers of connectors so they can't be reversed. Attach the 10 qty. connector socket to the **G** PCB & the 11 qty. connector housing to the **H** PCB. Connect the 3 wire socket on the **G** PCB to the pins on the **F** PCB. Make certain that the label marked "**TOP FACING**" is toward you as shown in the **STEP 1** photo.

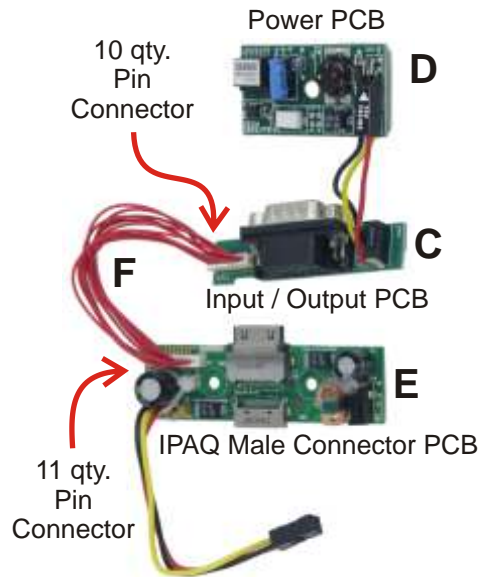

STEP 1

STEP 2



Model	Serial	Pass Through	Power	PCB Washer	Washer For Nut
h1900	NO	NO	NO	NA	NA
h2200	YES	YES	YES	WHITE, BLACK	BLUE, RED
hx2415	YES	YES	YES	WHITE, BLUE, RED	GREEN
rx3115	YES	NO	YES	WHITE, BLUE	GREEN
3650	NO	NO	NO	NA	NA
3955	YES	YES	YES	RED	WHITE, GREEN, BLUE
h4100	YES	YES	YES	WHITE, BLACK, RED	BLUE
h4300	YES	YES	YES	GREEN, RED	WHITE, BLUE
hx4700	YES	YES	YES	GREEN	WHITE, BLUE
h5555	YES	YES	YES	RED	WHITE, GREEN, BLUE
h6315	NO	YES	YES	WHITE	GREEN

Step 2 Before the proceeding look at the pictures in **Step 2** and specifically how the **E** PCB is attached to **A** housing. Check the **E PCB Application Chart** to see what **M** washers are required for your iPAQ model. Install the **K** screws in **E** PCB along with the nuts & appropriate colored washers **M** to properly space the **E** PCB to align with the iPAQ device. Make certain to have the **K** screws, nuts & correct **M** washers on the correct side of the PCB. The **K** nut must have a **M** washer under it or the PCB may be damaged. **IMPORTANT: DON'T OVER TIGHTEN ANY NUTS, OR SCREWS IN THE REMAINING STEPS.** Insert the iPAQ device into the cradle and carefully align the **E** PCB into the mating connector. The 2 qty **K** hex head screws will slide into the **A** housing. Make certain the **E** PCB is fully engaged into the iPAQ device and then gently tighten the **K** nylock nuts.

STEP 3



STEP 4 & 5



Step 3 Install **C** PCB & **D** PCB into **B** cover and secure **D** PCB with **J** screw. Make certain that the 3 pins in **B** cover align with the 3 holes in **D** PCB. cover with the 2 screws (**C**).

Step 4 With iPAQ device still installed in **A** housing attach **B** cover with **A** housing using **L** screws. Note; make certain screws are properly aligned and **DON'T OVER TIGHTEN.**

Step 5 Attach **G** side arms with **H** screws and nuts. With iPAQ device installed in **A** housing, **G** adjust arms and **GENTLY** tighten screws. Note, insert 4 qty. business cards between the side arms and the iPAQ device to provide the proper clearance for easy use.

Your RAM Powered Docking Cradle is now ready for use.